

3/8" - 1"

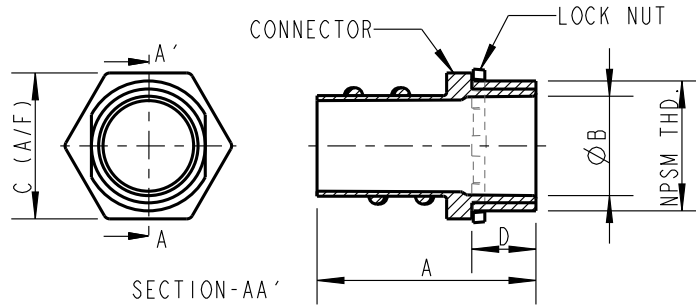

1-1/4" - 2"

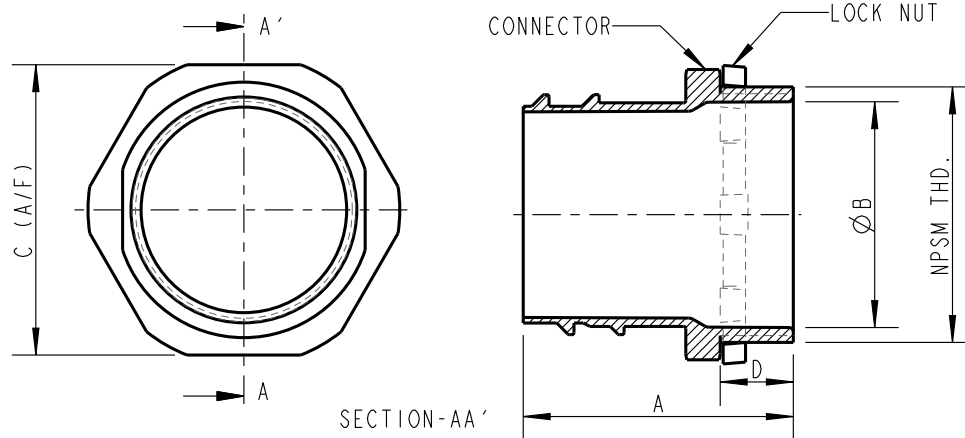

ITEM	CAT #	SIZE	A	ØB	C (HEX.)	D
001	XC 240	3/8"	32.5 (1.280)	15.5 (0.610)	23.2 (0.913)	9.0 (0.354)
002	XC241	1/2"	32.5 (1.280)	16.0 (0.630)	23.4 (0.921)	9.0 (0.354)
003	XC 242	3/4"	38.0 (1.496)	20.5 (0.808)	30.0 (1.181)	10.0 (0.394)
004	XC 243	1"	47.5 (1.870)	26.0 (1.024)	35.5 (1.398)	14.0 (0.551)
005	XC 244	1-1/4"	54.0 (2.126)	34.5 (1.358)	44.3 (1.744)	14.5 (0.571)
006	XC 245	1-1/2"	59.0 (2.323)	41.0 (1.614)	53.5 (2.106)	15.5 (0.610)
007	XC 246	2"	63.0 (2.480)	52.0 (2.047)	67.5 (2.657)	16.5 (0.649)

NOTES:

- CAT.#s MAY ALSO EXIST WITH THE FOLLOWING SUFFIXES -1, -2, -5 OR -50CP;
- MATERIAL: DIE CAST ZINC.

GENERAL NOTES		 A Member of the ABB Group			
1. ALL DIMENSIONS ARE FOR REFERENCE ONLY. 2. DIMENSIONS IN BRACKETS [] ARE IN METRIC UNITS.					
REVISIONS		DESCRIPTION:			
0 SEE ERN (****) FOR APPROVAL SIGNATURES & RELEASE DATE. PROJECT NO: ****		SCREW IN CONNECTOR			
		ORIGINAL PROJECT NO / (ERN NO)	SHEET NO:	REV. NO:	DRAWING NO:
		010M001470 / (2018665)	1 OF 1	0	WSD-002551